

SPECIFICATIONS	
CONTACT CARRIER MATERIAL	NYLON
CONTACT MATERIAL/PLATING	BRASS/GOLD
RATED CURRENT [A]	2.0 A
RATED VOLTAGE [V]	60 VAC/75 VDC
HOUSING/LOCKNUT MATERIAL/PLATING	BRASS/NICKEL
NUMBER OF CONDUCTORS [AWG]	10x24 AWG
TEMPERATURE RATING	-40°C to +105°C (-40°F to +221°F)
PROTECTION CLASS	MEETS NEMA 1,3,4,6P AND IEC IP68
MAX. PANEL THICKNESS	3.0 [0.12]

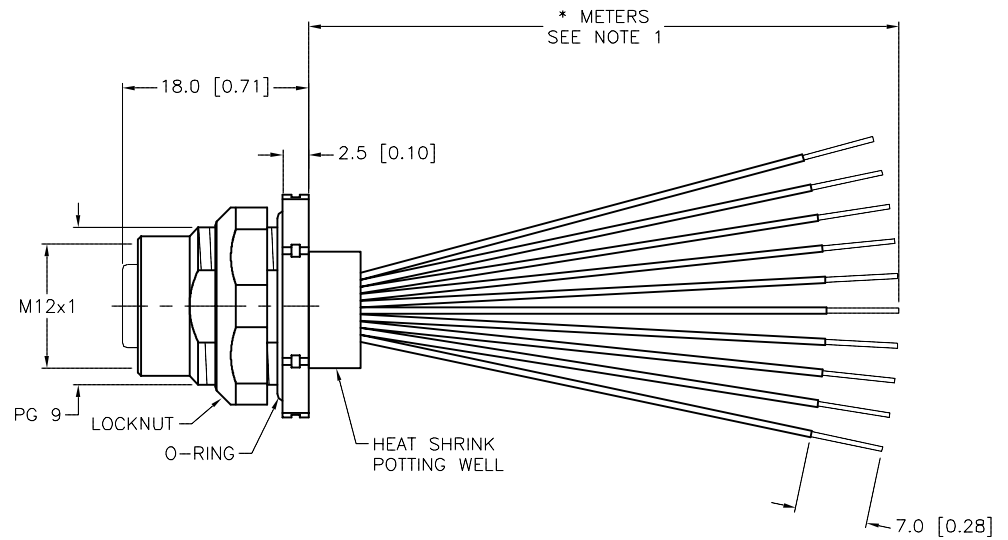
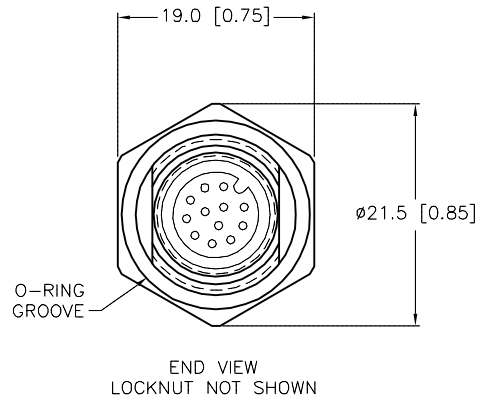

CABLE LENGTH	TOLERANCE *
ALL LENGTHS	+ 4% (OR 50mm) OF LENGTH - 0% (OR 0mm) OF LENGTH WHICHEVER IS GREATER
STRIP LENGTH	TOLERANCE *
0-7mm	±0.5mm
8-29mm	±1.0mm
30-49mm	±2.0mm
50-69mm	±3.0mm
70-100mm	±4.0mm
OVER 100mm	±5.0mm

*** UNLESS OTHERWISE SPECIFIED**

SOURCE DRAWING - FOR REFERENCE ONLY

NOTES:

1. "*" INDICATES LEAD LENGTH IN METERS. CONTACT TURCK TO ORDER SPECIFIC LENGTHS.

RELATED DOCUMENTS	3RD ANGLE PROJECTION	THIS DRAWING IS CONFIDENTIAL AND THE PROPERTY OF TURCK INC. USE OF THIS DOCUMENT WITHOUT WRITTEN PERMISSION IS PROHIBITED.	TURCK INC High Technology Sensors and Automation Controls 3000 CAMPUS DRIVE MINNEAPOLIS, MN 55441 1-800-544-7769 (763) 553-7300 (763) 553-0708 fax turck.com	
1.		DRFT RDS	DATE 10/24/03	DESCRIPTION FKFD 10-*
2.		DSGN	SCALE 1=.8	
3.	ALL DIMENSIONS DISPLAYED ON THIS DRAWING ARE FOR REFERENCE ONLY	UNIT OF MEASUREMENT MILLIMETER [INCH]		IDENTIFICATION NO.
4.		CONTACT TURCK FOR MORE INFORMATION		
MATERIAL	SEE SPECIFICATIONS	DO NOT SCALE THIS DRAWING		FILE: 777002678
FINISH	SEE SPECIFICATIONS	SHEET 1 OF 1		

C	ADD HEAT SHRINK POTTING WELL	TR	04/01/09	25713
REV	DESCRIPTION	BY	DATE	ECO NO.